

Behälter mit Räder

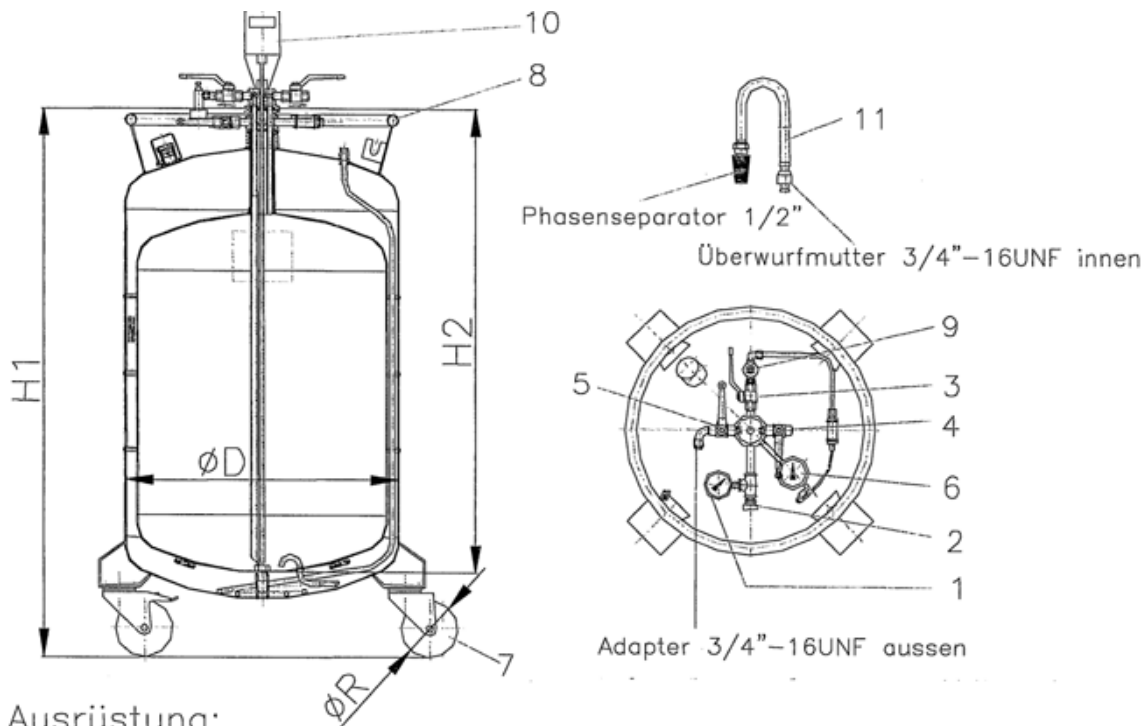



Ausrüstung:

- | | |
|---|---|
| 1 Manometer | 7 Lenkrollen |
| 2 Sicherheitsventil | 8 Handring |
| 3 Absperrventil 3/8"-Druckaufbau | 9 autom. Druckregelventil – optional |
| 4 Absperrventil 3/8"-Druckentlastung/Entnahme Gas | 10 Inhaltsanzeige Digital – optional |
| 5 Absperrventil 3/8"-Befüllung/Entnahme Flüssig | 11 flex. Edeltstahlschlauch DN10
mit Phasenseparator |
| 6 Inhaltsanzeige auf Differenzdruckbasis-
Standardausführung | |

Maße(mm)	Nutzinhalt /Ltr.	Betr. Überdr. /bar	Betr. Temp. /°C	Gewicht(leer) /kg	$\varnothing D$	H1	H2	$\varnothing R$
CS30SK	30	1,5bar	-196°C	42	450	680	535	100
CS60SK	60	1,5bar	-196°C	47	450	1100	795	100
CS100SK	100	1,5bar	-196°C	61	550	1030	637	125
CS120SK	120	1,5bar	-196°C	70	550	1250	940	125
CS160SK	160	1,5bar	-196°C	95	600	1200	1025	125
CS200SK	200	1,5bar	-196°C	120	700	1200	960	160
CS250SK	250	1,5bar	-196°C	141	700	1370	1120	160
CS300SK	300	1,5bar	-196°C	150	700	1540	1190	160
CS400SK	400	1,5bar	-196°C	170	900	1375	1152	200
CS450SK	450	1,5bar	-196°C	180	900	1410	1191	200
CS600SK	600	1,5bar	-196°C	260	1000	1650	1420	200
CS800SK	800	1,5bar	-196°C	340	1100	1680	1435	200
CS1000SK	1000	1,5bar	-196°C	390	1300	1850	2095	200